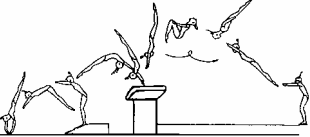
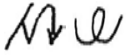
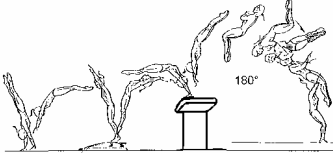
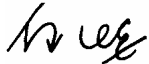
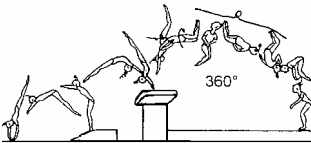
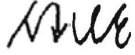
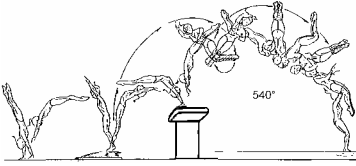
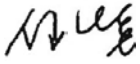
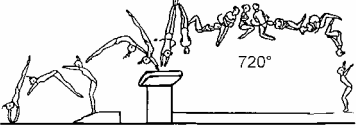
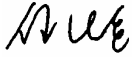
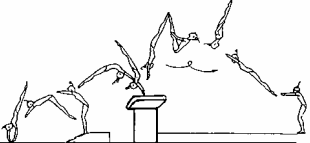
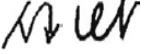
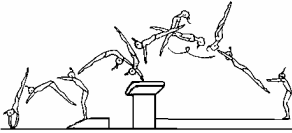
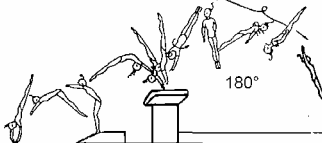
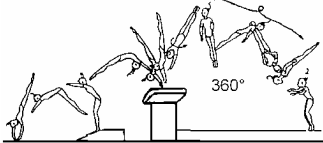
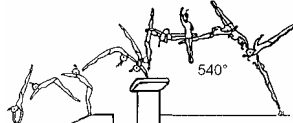
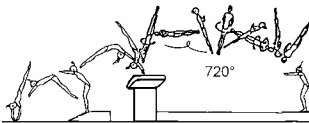
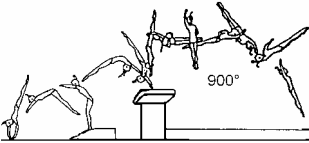
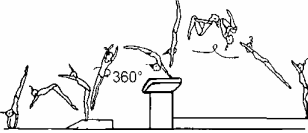
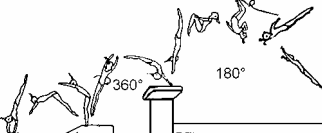
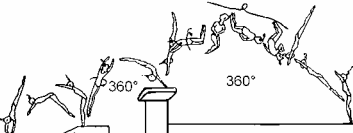

SKUPINA 4 - PŘESKOKY PO RONDATU I S OBRATEM 360° V PRVNÍ LETOVÉ FÁZI - SALTA VZAD I S OBRATY KOLEM PODÉLNÉ OSY VE DRUHÉ LETOVÉ FÁZI

<p>4.10 Rondat a přemet vzad - salto vzad skrčmo</p> <p style="text-align: right;">3.80 b.</p>  	<p>4.11 Rondat a přemet vzad - salto vzad skrčmo s obr. 180°</p> <p style="text-align: right;">4.10 b.</p>  	<p>4.12 Rondat a přemet vzad - salto vzad skrčmo s obr. 360°</p> <p style="text-align: right;">4.40 b.</p>  	<p>4.13 Rondat a přemet vzad - salto vzad skrčmo s obr. 540°</p> <p style="text-align: right;">4.90 b.</p>  	<p>4.14 Rondat a přemet vzad - salto vzad skrčmo s obr. 720° (Dungelova)</p> <p style="text-align: right;">5.20 b.</p>  	
<p>4.20 Rondat a přemet vzad - salto vzad schylmo</p> <p style="text-align: right;">4.00 b.</p>  					

SKUPINA 4 - PŘESKOKY PO RONDATU I S OBRATEM 360° V PRVNÍ LETOVÉ FÁZI - SALTA VZAD I S OBRATY KOLEM PODÉLNÉ OSY VE DRUHÉ LETOVÉ FÁZI

<p>4.30 Rondat a přemet vzad - salto vzad prohnutě</p> <p style="text-align: right;">4.40 b.</p>  <p style="text-align: center;"><i>NW</i></p>	<p>4.31 Rondat a přemet vzad - salto vzad prohnutě s obr. 180°</p> <p style="text-align: right;">4.70 b.</p>  <p style="text-align: center;"><i>NW 180°</i></p>	<p>4.32 Rondat a přemet vzad - salto vzad prohnutě s obr. 360°</p> <p style="text-align: right;">5.00 b.</p>  <p style="text-align: center;"><i>NW 360°</i></p>	<p>4.33 Rondat a přemet vzad - salto vzad prohnutě s obr. 540°</p> <p style="text-align: right;">5.50 b.</p>  <p style="text-align: center;"><i>NW 540°</i></p>	<p>4.34 Rondat a přemet vzad - salto vzad prohnutě s obr. 720°</p> <p style="text-align: right;">5.80 b.</p>  <p style="text-align: center;"><i>NW 720°</i></p>	<p>4.35 Rondat a přemet vzad - salto vzad prohnutě s obr. 540° (Amanar)</p> <p style="text-align: right;">6.50 b.</p>  <p style="text-align: center;"><i>NW 540°</i></p>
<p>4.40 Rondat a přemet vzad s obr.360° - salto vzad skrčmo (Luconi)</p> <p style="text-align: right;">4.60 b.</p>  <p style="text-align: center;"><i>NW 360°</i></p>	<p>4.41 Rondat a přemet vzad s obr.360° - salto vzad skrčmo s obr. 180°</p> <p style="text-align: right;">4.90 b.</p>  <p style="text-align: center;"><i>NW 360° 180°</i></p>	<p>4.42 Rondat a přemet vzad s obr.360° - salto vzad skrčmo s obr. 360°</p> <p style="text-align: right;">5.20 b.</p>  <p style="text-align: center;"><i>NW 360° 360°</i></p>			

SKUPINA 4 - PŘESKOKY PO RONDATU I S OBRATEM 360° V PRVNÍ LETOVÉ FÁZI - SALTA VZAD I S OBRATY KOLEM PODÉLNÉ OSY VE DRUHÉ LETOVÉ FÁZI

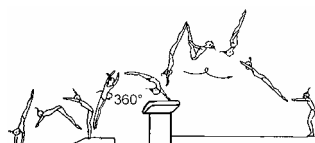
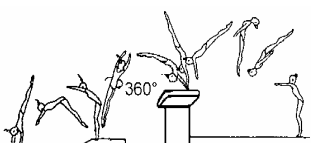
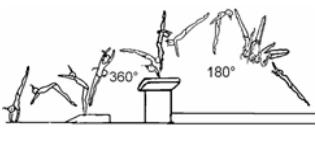
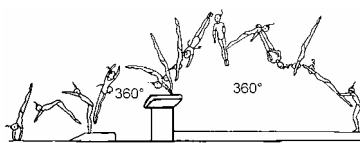
<p>4.50 Rondat a přemet vzad s obr. 360° - salto vzad schylo</p> <p style="text-align: right;">4.80 b.</p>  <p style="text-align: center;"><i>Handwritten notation: N62 W</i></p>	<p>4.51 Rondat a přemet vzad s obr. 360° - salto vzad prohnuté</p> <p style="text-align: right;">5.20 b.</p>  <p style="text-align: center;"><i>Handwritten notation: N62 W</i></p>	<p>4.52 Rondat a přemet vzad s obr. 360° - salto vzad prohnuté s obr. 180°</p> <p style="text-align: right;">5.50 b.</p>  <p style="text-align: center;"><i>Handwritten notation: N62 W E</i></p>	<p>4.53 Rondat a přemet vzad s obr. 360° - salto vzad prohnuté s obr. 180°</p> <p style="text-align: right;">5.80 b.</p>  <p style="text-align: center;"><i>Handwritten notation: N62 W E</i></p>		
---	--	---	--	--	--